

**Technical Report
DSL Forum
TR-110**

**DSLHome™
Reference Models for VoIP Configurations in the
DSL Home**

September 2005

**Produced by:
DSL Home Technical Working Group**

**Editors: Robert McDougall, Bell Canada
Barbara Stark, BellSouth**

**Working Group Co-Chairs:
Greg Bathrick, Texas Instruments
George Pitsoulakis, Westell**

Abstract:

This document illustrates and describes reference models for VoIP CPE Configurations. This document is focused solely on VoIP CPE technologies addressing the Consumer market. This document will not attempt to define the technical requirements for any of these configurations.

Notice:

The DSL Forum is a non-profit corporation organized to create guidelines for DSL network system development and deployment. This Technical Report has been approved by members of the Forum. This document is not binding on the DSL Forum, any of its members, or any developer or service provider involved in DSL. This document is subject to change, but only with approval of members of the Forum.

©2004 Digital Subscriber Line Forum. All Rights Reserved.

DSL Forum technical reports may be copied, downloaded, stored on a server or otherwise re-distributed in their entirety only.

Notwithstanding anything to the contrary, the DSL Forum makes no representation or warranty, expressed or implied, concerning this publication, its contents or the completeness, accuracy, or applicability of any information contained in this publication. No liability of any kind shall be assumed by the DSL Forum as a result of reliance upon any information contained in this publication. The DSL Forum does not assume any responsibility to update or correct any information in this publication.

DSLHome™
Reference Models for VoIP Configurations in the DSL Home

Table of Contents

1	SCOPE AND PURPOSE.....	1
1.1	INTRODUCTION	1
1.2	PURPOSE	1
1.3	SCOPE.....	1
1.4	RELATION TO OTHER STANDARDS AND FORUMS	1
1.4.1	TR-094 Reference Architecture.....	1
2	REFERENCE MODELS FOR VOIP CONFIGURATIONS	3
2.1	STANDALONE ATA	3
2.2	NATIVE IP PHONE	3
2.3	TYPICAL PC SOFTPHONE.....	4
2.4	RG WITH EMBEDDED ATA FUNCTIONALITY	4
2.5	RG WITH VOIP TO VOIP PROXY CAPABILITY	5
2.6	RG WITH VOICE TO VOIP GATEWAY CAPABILITY.....	5
3	CHALLENGES FOR MASS MARKET ADOPTION OF VOIP.....	6
4	CONTINUOUS VOICE OPERATIONS.....	7
4.1	CONTINUOUS VOICE OPERATION FOR A STANDALONE ATA – UPS	7
4.2	CONTINUOUS VOICE OPERATION FOR A STANDALONE ATA – POTS FAILOVER.....	8
4.3	CONTINUOUS VOICE OPERATIONS FOR AN EMBEDDED ATA – UPS	8
4.4	CONTINUOUS VOICE OPERATION FOR AN EMBEDDED ATA – POTS FAILOVER	9
5	GLOSSARY.....	10

1 SCOPE AND PURPOSE

1.1 Introduction

The ever increasing adoption of high speed DSL internet services by Consumers has resulted in a marketplace whereby many end users now have sufficient bandwidth to support Voice over IP (VoIP) bandwidth requirements. Further, VoIP technology has matured significantly in recent years resulting in initial mass market deployments by many DSL service providers. As a result, it is now appropriate to focus industry attention and ensure consensus and standardization around VoIP CPE technology addressing the Consumer marketplace.

1.2 Purpose

The purpose of this working text is to:

1. Drive consensus on the various configurations in which a VoIP service may be instantiated within the DSL Home. The configurations defined herein may not represent an exhaustive list but rather the most probable configurations identified presently.
2. Suggest priorities for subsequent work addressing the technical requirements of these configurations.
3. Raise issues that will be encountered with respect to the support of VoIP within the DSL Home including continuous voice operation, CPE interfaces, impacts of network address and port translation (NAPT) and Quality of Service (QoS).

1.3 Scope

This working text is focused solely on VoIP CPE technologies addressing the Consumer market. That said, these configurations may be suitable for small and medium business applications as well as enterprise applications in the case of teleworkers.

This document illustrates and describes reference models for VoIP Configurations and continuous voice operation. This document will not attempt to define the technical requirements for any of these configurations.

For purposes of clarity, analog telephones associated with POTS services delivered in parallel with the DSL broadband service are NOT shown. Also, personal computers are not shown unless they form part of the voice solution.

1.4 Relation to Other Standards and Forums

This working text complements other work of the DSL Forum, including TR-094 (Multi-Service Delivery Framework for Home Networks), and TR-059 (DSL Evolution - Architecture Requirements for the Support of QoS-Enabled IP Services).

1.4.1 TR-094 Reference Architecture

Many of the illustrations in the following pages are derived from the architecture presented with TR-094 (Multi-Service Delivery Framework for Home Networks).

The function of the R interface (relative to the discussion of delivery of VoIP services into the customer premises) is to present a standard Tip and Ring Interface in order to allow for the connectivity of analog

telephones into the DSL Home Network Architecture (TR-094) via an analog telephone adapter (ATA) or similar VoIP device.

A Supplementary Application Network can be used to transport voice by using mechanisms that are not IP based.

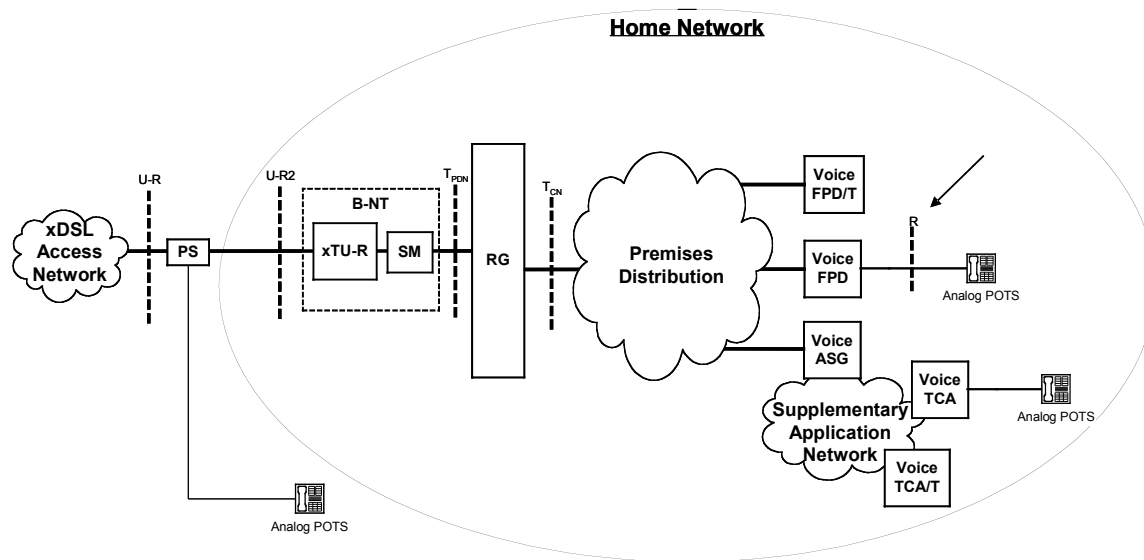

R = T/R Analog

TCA = Thin Client Adaptor

In the illustrations in the following sections, the presence of a broadband access line and RG as defined in the DSL Forum's HN architecture (TR-094) is assumed.

2 REFERENCE MODELS FOR VOIP CONFIGURATIONS

The following presents examples of VoIP Consumer CPE Configurations within the DSL Home. The configurations defined herein may not represent an exhaustive list but rather the most probable configurations identified presently. It should be noted that these configurations are not mutually exclusive and combinations of the following may exist within the same DSL Home.

2.1 Standalone ATA

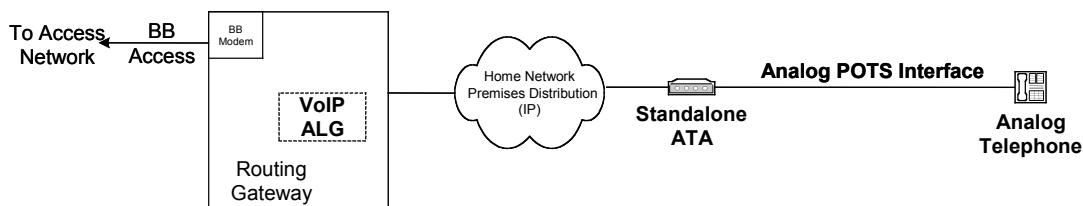

The Standalone ATA configuration represents a simple and straight forward VoIP configuration. In this configuration, the ATA is physically separate from both the Analog Telephone and the Routing Gateway (RG). The ATA processes the VoIP call on behalf of the analog telephone. As such, the ATA meets the generic definition of a Functional Processing Device (FPD) as defined in TR-094. The ATA enables a standard analog telephone to take advantage of the VoIP service. In this configuration, the RG may have no VoIP awareness/capabilities and or have a VoIP application layer gateway (ALG). The ATA may have multiple physical ports for supporting multiple derived lines.

2.2 Native IP Phone

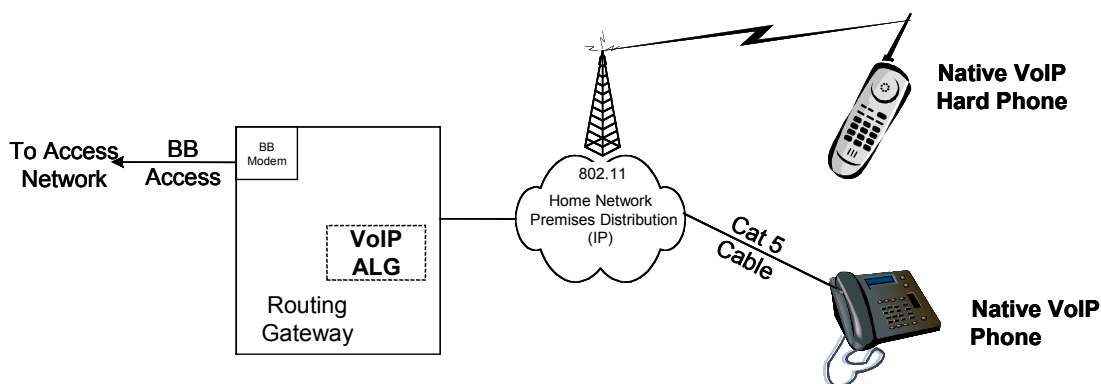

In this configuration, VoIP processing is done on the end user device. In this instance, the Native IP Phone is both the Functional Processing Device and End User Terminal FPD/T (as defined in TR-094). The Native IP Phone is IP aware and is designed for IP networks. The connection to the IP Network may be via a wired or wireless interface. This may be accomplished by a multi-mode phone which will support digital, Wi Fi or analog modes of communication. In this configuration the RG may have no VoIP awareness/capabilities or have a VoIP application layer gateway (ALG).

2.3 Typical PC Softphone

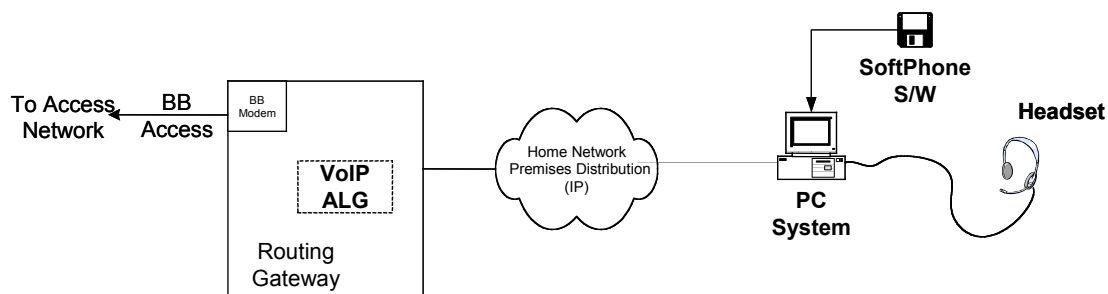

In this scenario, the VoIP functionality is added to the PC via VoIP Software (3rd party or part of the PC operating system) and it is this VoIP software, embedded within the PC, which processes the VoIP call. A speaker and microphone are also required for VoIP operation. These may be either internal to the PC or added as external peripherals, e.g., a headset. The RG may have no VoIP awareness/capabilities or have a VoIP application layer gateway (ALG).

2.4 RG with Embedded ATA Functionality

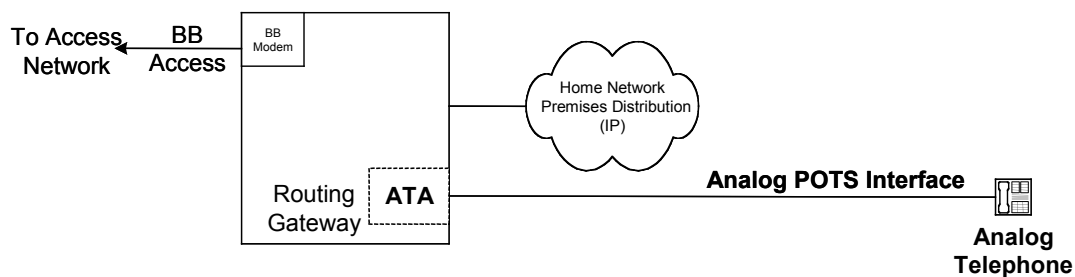

This configuration is similar to the configuration of a Standalone ATA presented in section 2.1. In this configuration, the ATA functionality is physically located or embedded within the RG. The ATA processes the VoIP call and presents it to the analog telephone via the standard analog telephone interface located within the RG. In this configuration the RG is VoIP aware. The RG with embedded ATA functionality may have more than one physical port for supporting multiple derived lines.

This solution avoids NATP (network address and port translation) issues, and therefore does not benefit from or require a VoIP application layer gateway (ALG).

2.5 RG with VoIP to VoIP Proxy Capability

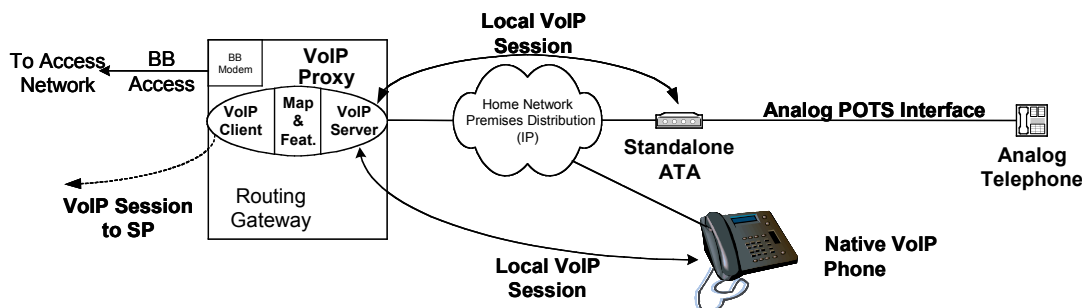

The RG with VoIP Proxy Capability may not initially be an attractive VoIP implementation; however it is presented here as a possible configuration.

In this configuration, the RG is enhanced with a VoIP proxy function to support more advanced intra-home features and capabilities like intercom, room to room video and advanced call routing capabilities. The VoIP proxy feature could also facilitate interworking of different VoIP protocols running on the WAN and the home network.

In the case where the VoIP Proxy function uses SIP, this function appears as a SIP VoIP service to all the VoIP phones in the home, regardless of their type (e.g., native phone or ATA.) The SIP sessions from these devices are terminated by the proxy function in the RG rather than at a VoIP service provider. This permits intra-home calling without the need for any external SIP service infrastructure.

On the WAN side, the VoIP proxy function appears as a regular VoIP client to the VoIP service. Any calls originating from one of the local phones and destined for a remote location would be signalled locally between the phone and the VoIP proxy. The VoIP proxy would recognize the call as going out and would invoke the VoIP client function to set up the call over the WAN using the VoIP service provider.

It is the separation of the home VoIP network and the WAN VoIP service that creates the potential for implementation of advanced VoIP capabilities and features

This solution avoids NAPT (network address and port translation) issues, and therefore does not benefit from or require a VoIP application layer gateway (ALG).

2.6 RG with Voice to VoIP Gateway Capability

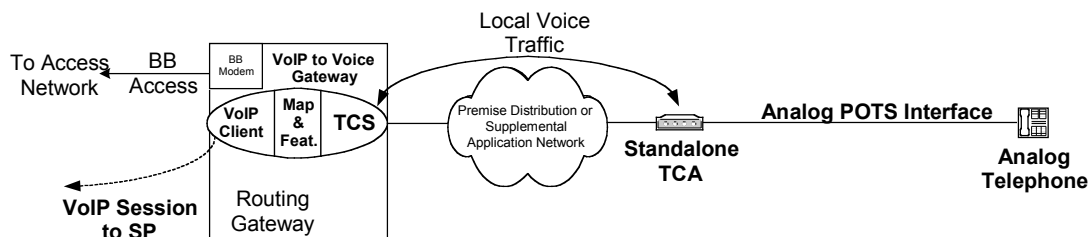

The RG with Voice to VoIP Gateway Capability allows the RG to act as the VoIP endpoint in the customer premises, and support multiple thin-client voice endpoints inside the premises.

This solution uses non-IP based transport between the Thin Client Adapter (TCA) and RG. Because it is non-IP, this solution may or may not use the IP Home Network Premises Distribution depending on the capability of that network to support non-IP protocols.

On the WAN side, the RG appears as a regular VoIP client to the VoIP service. Any calls originating from one of the local phones and destined for a remote location would be signalled locally between the phone and the RG's TCS function. The RG would recognize the call as going out and would invoke the VoIP client function to set up the call over the WAN using the VoIP service provider.

Examples of this sort of configuration include Voice over HPNA and Digital Enhanced Cordless Telecommunications (DECT). Others may be possible.

As with the VoIP Proxy Capability, it is the separation of the home VoIP network and the WAN VoIP service that creates the potential for implementation of advanced VoIP capabilities and features

This solution avoids NAT (network address and port translation) issues, and therefore does not benefit from or require a VoIP application layer gateway (ALG).

3 CHALLENGES FOR MASS MARKET ADOPTION OF VOIP

As was indicated in section 1.2 of this working text, there are a number of challenges that have been identified and researched in order to ensure a viable mass market VoIP service in each of the VoIP CPE Configurations defined above. The principal challenges are:

1. Continuous voice operations (see below)
2. Network Address Port Translation (NAPT)
3. 911 and Enhanced 911
4. Quality of Service (QoS)

4 CONTINUOUS VOICE OPERATIONS

Unlike standard POTS service, which is a combination of both a communication component and a power component (the power component is commonly “backed up” by batteries in the CO) a VoIP service only provides the communication component. The power for VoIP service is usually derived from commercial electrical sources and is therefore susceptible to interruption.

If a service provider wishes to maintain a VoIP telephone service during a commercial power failure, additional efforts will have to be made to ensure continuous voice operations. Generally speaking, there are two methods for achieving this end:

1. Utilizing a parallel POTS service with service continuity capabilities.
2. Utilizing an uninterruptible power source (UPS), e.g., internal batteries or standalone UPS. [Note that this power does not have to be supplied over conventional power lines, but may be supplied over phone lines, Ethernet cable, or other physical cables.]

The following illustrations show examples of continuous operation solutions for different VoIP configurations. It should be noted that various combinations of these techniques may be employed in real world implementations.

4.1 Continuous Voice Operation for a Standalone ATA – UPS

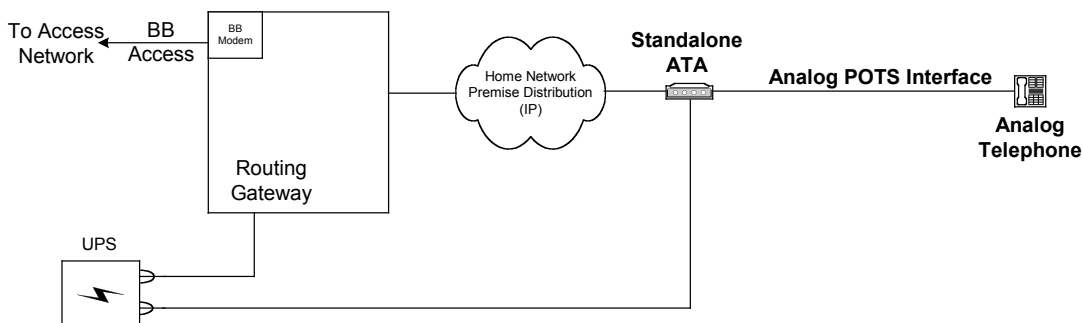

In the above example, both the RG and the Standalone ATA are plugged into a UPS. In this scenario, as both the RG and the ATA are plugged into a UPS, neither the RG nor the ATA would cease to function in the event of a commercial power failure, thereby ensuring a continuous VoIP service. In cases where a UPS is employed to ensure continuous voice service no standard POTS is required.

(Note: this assumes the analog telephone draws its power from the ATA device (standalone or embedded) via the T/R interface and that the analog telephone does not require supplementary powering from an external source.)

It should be noted that the UPS may be an external device as is depicted above or located within either the RG and or the ATA (internal batteries). If the Home Network elements and or premises distribution equipment used to network the RG to the ATA are not supplied with uninterruptible power, then UPS back-up of the RG and ATA will not ensure continuous voice service.

Power over Ethernet could be applied to eliminate the ATA/UPS connection in this configuration.

The power to the RG could be delivered over phone line, in some RG configurations. Other cabling media could also be used, depending on the capabilities of the RG, and the location and capabilities of the UPS.

4.2 Continuous Voice Operation for a Standalone ATA – POTS Failover

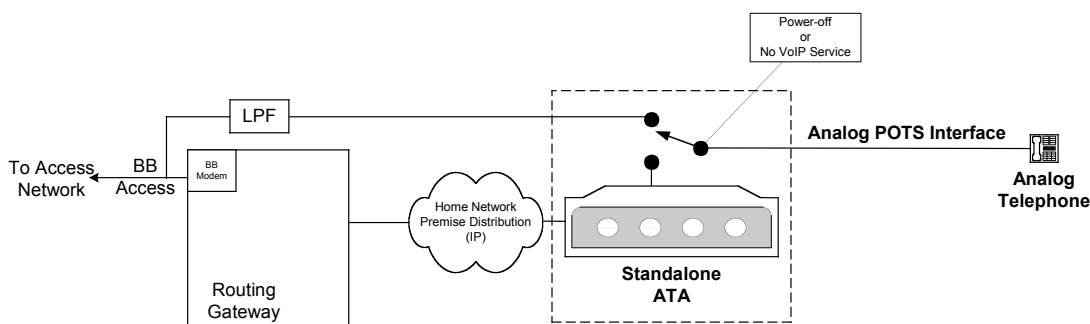

Under this scenario, the absence or loss of the VoIP service (which may be caused by power failure, loss of network connectivity, etc.) results in a physical switching of the connectivity of the analog POTS interface within the ATA, from the Home Network Premises Distribution, to the POTS service, which is present either on the BB access line or a separate line. Therefore, in order for a POTS failover to be provided, a POTS service must be present on a line inside the premises.

Additionally, and unlike Continuous Voice Operation via UPS defined in Section 3.1.1, the loss or termination of the VoIP service will also result in a “dropping” of any VoIP call on-going at the time of the termination or loss of the VoIP service. Once the physical switching of the analog POTS interface within the ATA is complete, subsequent calls via the analog telephone will continue over the POTS service until such time as the VoIP service is re-established.

Under this scenario, an extension of the POTS line to the ATA is required. In the case where the POTS and broadband service are present on the same line, appropriate filtering is needed to avoid both DSL and POTS service deterioration. POTS failover will require additional functionality within the ATA.

4.3 Continuous Voice Operations for an Embedded ATA – UPS

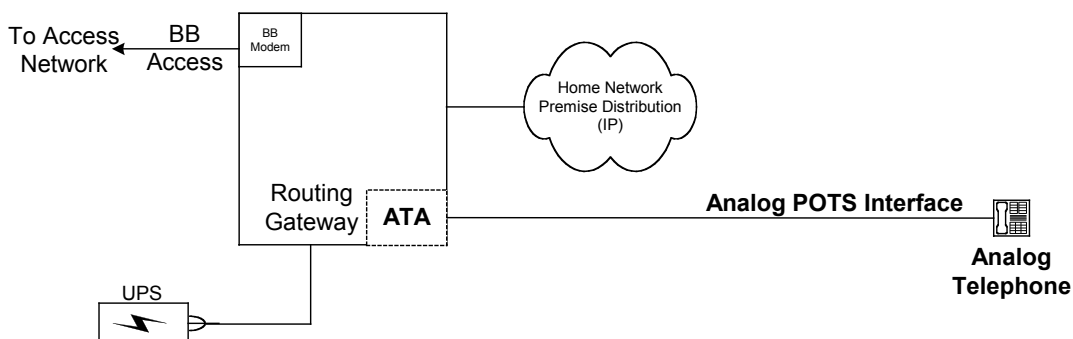

In the example given in section 3.1.1, both the RG and the Standalone ATA are plugged into an uninterruptible power source (UPS). In this example, only the RG will make use of a UPS (external or internal batteries) and the ATA will draw its power requirement during a power outage directly from the RG. In this scenario, the RG and hence ATA will not cease to function in the event of a commercial power

failure, thereby ensuring a continuous VoIP service. In cases where a UPS is employed to ensure continuous voice service no standard POTS is required.

This configuration reduces the number of UPS connections required relative to the configuration presented in Section 4.1.

(Note: the above assumes the analog telephone draws its power from the ATA device (embedded) via the T/R interface, and that the analog telephone does not require supplementary powering from an external source.)

The power to the RG could be delivered over phone line, in some RG configurations. Other cabling media could also be used, depending on the capabilities of the RG, and the location and capabilities of the UPS.

4.4 Continuous Voice Operation for an Embedded ATA – POTS Failover

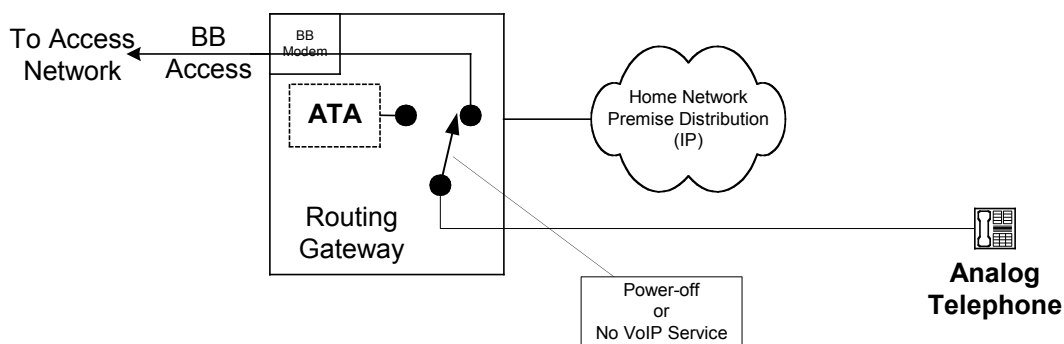

Similar to the scenario presented in Section 4.2, the absence or loss of the VoIP service (which may be caused by power failure, network connectivity, etc.) results in a physical switching of the connectivity of the analog POTS interface within the ATA (and hence RG), from the Home Network Premises Distribution, to the POTS service, which is present either on the BB access line or a separate line. Therefore, in order for a POTS failover to be provided, a POTS service must be present on a line inside the premises.

As was indicated in Section 4.2, and unlike Continuous Voice Operation via UPS defined in Section 4.1 and 4.3, the loss or termination of the VoIP service will also result in a “dropping” of any VoIP call on-going at the time of the termination or loss of the VoIP service. Once the physical switching of the analog POTS interface with the ATA is complete, subsequent calls will continue over the POTS service until such time as the VoIP service is re-established.

Under this scenario, an extension of the POTS line to the ATA is required. In the case where the POTS and broadband service are present on the same line, appropriate filtering is needed in order to avoid both DSL and POTS service deterioration. POTS failover will require additional functionality within the RG.

5 GLOSSARY

ADSL	Asymmetric Digital Subscriber Line
ASG	Application Service Gateway
ASP	Application Service Provider
ATM	Asynchronous Transfer Mode
ATU-C	ADSL Termination Unit - Central Office (at Access Network end)
ATU-R	ADSL Termination Unit - Remote (at customer end)
BB	Broadband
B-NT	Broadband Network Termination
Cat5	Category 5
CATV	Cable TV
CO	Central Office
COAX	Co-axial cable
DHCP	Dynamic Host Configuration Protocol
DSL	Digital Subscriber Line
EUT	End User Terminal
FPD	Functional Processing Device
FPD/T	Functional Processing Device and Terminal
HN	Home Network
HPNA	Home Phoneline Networking Alliance
IEEE	Institute of Electrical and Electronics Engineers
IETF	Internet Engineering Task Force
IGMP	Internet Group Management Protocol
IP	Internet Protocol
IPCP	IP Control Protocol
ISP	Internet Service Provider
LAN	Local Area Network
MAC	Medium Access Control
NAPT	Network Address and Port Translation
PC	Personal Computer
PDN	Premises Distribution Network
POTS	Plain Old Telephone Service
PPPoE	Point-to-Point Protocol over Ethernet
PS	POTS Splitter
PVR	Personal Video Recorder
QoS	Quality of Service

VoIP Configurations within the DSL Home

WT-110

RF	Radio Frequency
RG	Routing Gateway
SIP	Session Initiation Protocol
SP	Service Provider
STB	Set Top Box
USB	Universal Serial Bus
VoIP	Voice over Internet Protocol
WAN	Wide Area Network